



*B260 Straw Blower
Straight Pull Trailer. (B260T)*

The FINN B260 Straw Blower is designed for maximum performance and operator convenience. It is widely considered the standard by which all straw and hay mulching equipment should be measured. With the highest material capacity in the industry (up to 20 tons/hour), the B260 handles the toughest material while performing at high levels of production and dependability. The B260 is the Straw Blower of choice for mine reclamation, highway construction, and large commercial sites.

Field Tested Tough. The B260 is the result of extensive research, field testing, and, most importantly, customer input. We asked the people that mean the most – the people who can quickly evaluate equipment as soon as they put it to the test on the job. We heard, “Give us a Straw Blower that gives the most for our equipment dollars.” With many features you just won’t find on other Straw Blowers, the B260 delivers.

Power & Control. The B260 Straw Blower features a John Deere Tier II turbo-charged diesel engine, coupled with a heavy-duty over-center clutch to provide smooth, high torque power to the blower. All controls are easily accessible from the operator’s seat, including the new digital engine information

display. The discharge tube has been designed to provide superior air flow, providing maximum discharge distance. The field-proven operator-controlled hydraulic (variable speed) power feed system is designed for reliable performance throughout the life of the machine. Its design eliminates the need for an extra person to hand feed, providing significant labor savings.

As the world leader for over 70 years in the design and manufacture of innovative, quality equipment for the erosion control industry, FINN Corporation is committed to your complete satisfaction.

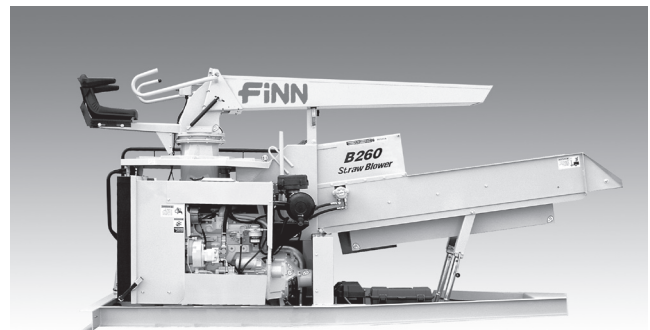

B260 Straw Blower Skid Mounted. (B260S)

Model shown may include optional equipment.

SMARTER WAYS TO WORK

9281 LeSaint Drive • Fairfield, OH 45014-5457 • Phone (513) 874-2818 • Fax (513) 874-2914
Toll Free (800) 543-7166 • Parts (800) 229-8707 • E-mail: sales@finncorp.com
Customer Service/Warranty (888) 382-1966

©2005 FINN Corporation

B260T TRAILER

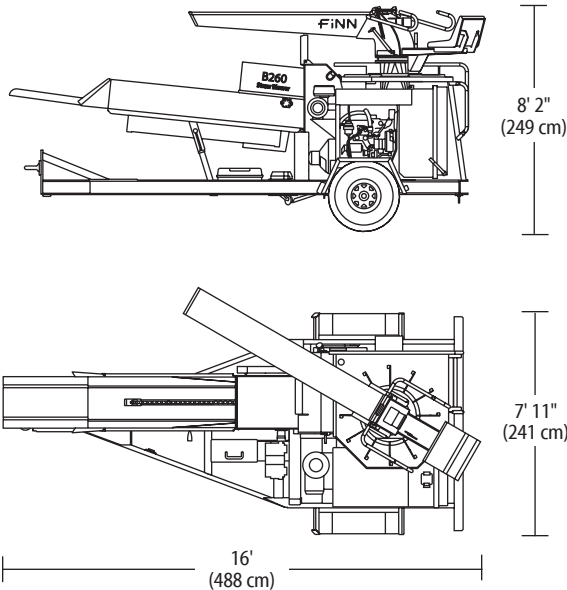

B260S SKID MOUNT

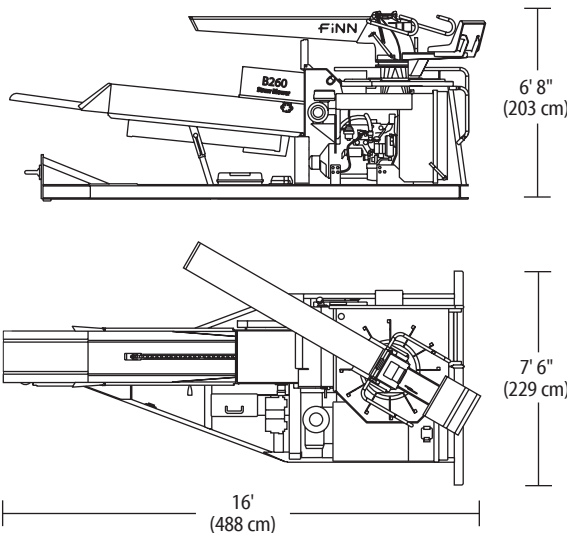

FINN MODEL B260 TECHNICAL SPECIFICATIONS

POWER	John Deere Tier II Diesel 4045T (4.5 liter), 115 hp Turbo with over-center clutch
ENGINE SAFETY SYSTEM	Engine ECU control with self diagnostics. Includes low oil pressure and high water temperature, automatic derate, and shut-off.
CAPACITY	Up to 20 tons of straw per hour
FUEL TANK CAPACITY	28 gallon (106 liter)
BLOWER.....	Dynamically balanced, 30" (76 cm) diameter fan with 6 blades developing a velocity greater than 185 mph (298 kph)
RANGE.....	Up to 100 ft. (30 m) in still air
FEED TRAY	Hydraulic powered conveyor chain with variable speed control. Tray includes an adjustable elevation and length to meet the bed of supply vehicle
BEATER CHAMBER.....	15 cu. ft. (425 liter) with 8 removable beater fingers for separating straw. Accepts both 2-string and 3-string rectangular bales
DISCHARGE TUBE	Ball bearing mounted. 355 degree horizontal rotation, 60 degree vertical travel with gas spring counter balance
FRAME & TRAILER	Heavy-duty 6" (15.2 cm) channel with a 6,000 lb. (2,730 kg) rubber torsion axle, 750 x 16 F rated highway tread, swing away parking jack, heavy-duty tow eye, fenders, flashing warning light, and DOT highway lights
OPERATOR STATION	Adjustable padded seat with fold-up arm rests mounted on the discharge head. Control panel includes digital engine information display, throttle, engine start/stop, horn and full discharge tube control. Centrally located power feed control and clutch lever within arms reach of operators station
DRIVES.....	Blower fan driven by power band belt. Feed chute roll and chain hydraulically driven with variable speed control
WEIGHT	B260T 4,800 lbs. (2,177 kg) B260S 4,400 lbs. (1,996 kg)
BRAKES.....	Electric with breakaway switch
OPERATOR SAFETY.....	Emergency shutdown buttons on feed tray and interlock switches on all access doors

FINN Corporation has a policy of continuous product improvement, and reserves the right to change design and specifications without notice.