

**FINN****HydroSeeder®****Series II****Model T90**

The superior technology behind the T90 Series II HydroSeeder is the result of more than 50 years of extensive FINN research and HydroSeeder manufacturing. Many customers have provided valuable input that shaped the final product. Today, the FINN T90 Series II HydroSeeder offers the ultimate in performance features and operator conveniences that are exactly what you'd expect from the industry leader in hydroseeding quality and innovation.

### **Even Application.**

For ease-of-use, the large loading hatch of the T90 Series II is located at the front of the unit. This allows material to be loaded from the tow vehicle while the operator stands safely on the hitch platform. A uniform mix is of vital importance and the FINN T90 Series II HydroSeeder delivers. The sleek design of the tank provides a smooth slurry flow pattern from the beginning to the end of the load.

### **Rugged & Aggressive.**

The FINN T90 Series II HydroSeeder features a heavy-duty agitator driven by a variable speed, reversible hydraulic motor – with controls both front and rear. The agitator and pump are independently driven, allowing complete mixing of the slurry without pump operation. This significantly

enhances mechanical longevity and flexibility during operation. Outstanding GPM output, piping, and pressure capabilities of the pump result in spray distances of up to 180 feet from the tower gun.

The T90 Series II HydroSeeder boasts a powerful centrifugal slurry pump, driven by an in-line common shaft clutch with no high-cost maintenance couplings, drive belts or hydraulic components. This configuration dramatically increases output and operating pressure.

### **Solid Performance.**

The independent torsion suspension axles of the T90 Series II are equipped with electric brakes for better control. Heavy-duty truck wheels with standard highway-rated tires provide solid stability on uneven terrain.

As the world leader for over 70 years in the design and manufacture of innovative, quality equipment for the green industry, and as the inventor of the HydroSeeder, FINN Corporation is committed to your complete satisfaction.

*Model shown may include optional equipment.*



# HydroSeeder®

## Series II

## Model T90 with Tier 4F Engine

### T90T TRAILER

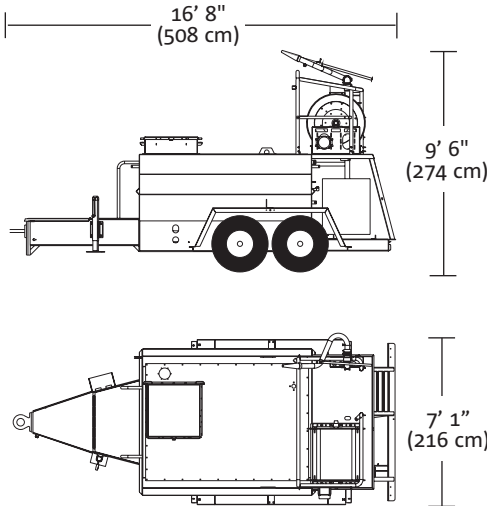

### T90S SKID MOUNT

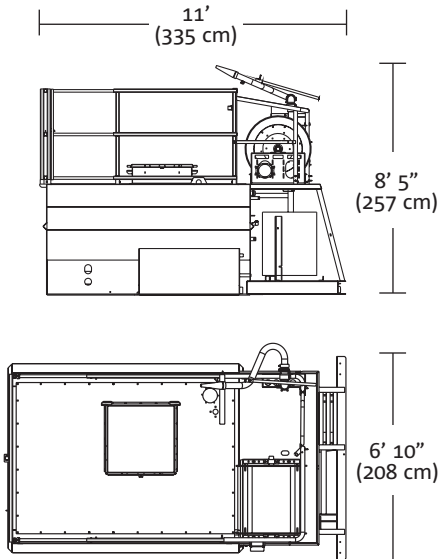

Shown with optional hose reel.

### FINN MODEL T90 TECHNICAL SPECIFICATIONS

- POWER..... Yanmar 3TNV88C-DYEM, 35.1hp (26.2kw), 3 cylinder water cooled diesel engine with over-center clutch. Tier 4Final. 1.642L
- ENGINE SAFETY SYSTEM ..... Low oil pressure, high temperature shutoff
- TANK SIZE..... 940 gallon (3,558 liter) liquid capacity, 800 gallon (3,028 liter) working capacity
- LOADS PER ACRE<sup>1</sup>.....3.75
- FUEL TANK CAPACITY ..... 13.5 gallon (51.1 liter)
- PUMP ..... Centrifugal 4" x 2" (10 cm x 5 cm) 170 gpm @ 100 psi, (646 lpm @ 7 kg/cm<sup>2</sup>), 3/4" (1.9 cm) solid clearance, external adjustment
- PUMP DRIVE..... Direct drive with over center clutch, pump drive is independent of agitator operation
- AGITATION ..... Mechanical paddle agitation and liquid recirculation
- AGITATOR DRIVE..... Reversible, variable speed hydraulic motor drive (0-95 rpm)
- DISCHARGE DISTANCE..... Up to 180 feet (55 m) from end of discharge tower
- MAX. MATERIAL CAPACITY ..... 2,500 lbs. (1,134 kg) granular solids, 400 lbs. (181 kg) fiber mulch
- NOZZLES..... (1) narrow fan, (1) wide fan, (2) long distance
- |                                 |      |                       |
|---------------------------------|------|-----------------------|
| EMPTY WEIGHT <sup>2</sup> ..... | T90T | 5,620 lbs. (2,549 kg) |
|                                 | T90S | 4,200 lbs. (1,905 kg) |
- |                                   |      |                        |
|-----------------------------------|------|------------------------|
| WORKING WEIGHT <sup>2</sup> ..... | T90T | 14,870 lbs. (6,745 kg) |
|                                   | T90S | 13,450 lbs. (6,101 kg) |
- BRAKES..... Electric on both axles with break-away switch
- LIGHTS..... D.O.T. including marker, identification lights and license plate bracket
- TIRES ..... ST225/90D16 load range E
- TRAILER AXLES ..... Tandem 7,000 lbs. (3,176 kg) rubber torsion with adjustable fenders.
- HITCH WEIGHT ..... Approx. 1,600 lbs. (762 kg)

<sup>1</sup>Loads per acre based on an application rate of 1500 lbs. mulch/acre.

<sup>2</sup>Weights are preliminary. Working weights are approximate and do not include stored materials.

FINN Corporation has a policy of continuous product improvement, and reserves the right to change design and specifications without notice.

HydroSeeder® and the FINN Design® Logo are registered trademarks of FINN Corporation.

