

# FT42500C

Track Mounted Crushing Plant Open Circuit

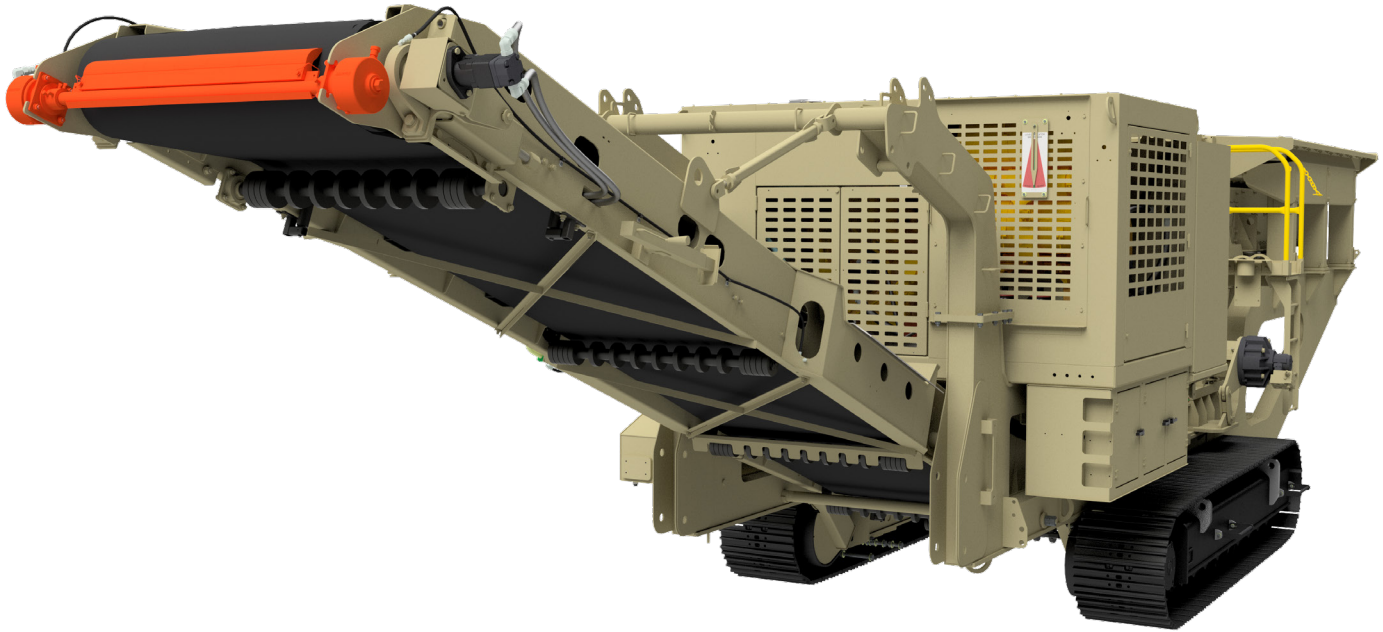

## Vibrating Grizzly Feeder

- 50" (1270mm) x 18' (5.5m) Vibrating Pan Feeder
- 6.5 cubic yard hopper with fixed walls
- 5' step-deck grizzly fingers 1.5" nominal spacing
- Bypass chute with flop gate

## Impact Crusher - HSI

- HSI opening height - 36" (914mm) HSI width - 50" (1270mm)
- 3 bar MPR rotor
- Multiple blow bar chemistries available to fit application
- Two (2) fully lined aprons
- Minimum apron settings - primary 2", secondary 1"
- Hydraulic adjustment
- RPM maximums vary on application and rotor
- Hydraulically actuated rear access

## Under Crusher Conveyor

- 48" (1200mm) fixed height with full spill boards
- Impact bed, 360PIW single ply
- Easily removed for maintenance

## Chassis

- Sculpted frame design
- 24" (600mm) tracks with dual drive
- Track length 12' 6" (3.6m)
- Balanced for zero cribbing
- Dust suppression with manifold

## Power And Controls

- CAT C13 440hp / 328kw Tier 4 Final
- 150gal (568L) fuel tank
- 200gal (757L) oil reservoir
- One 12GPM and one 20GPM hydraulic circuits for magnet, side delivery, or auxiliary
- Radio remote / tether control system
- OPS 7 with push button or touchscreen
- Crusher CSS adjusted safely at control panel
- Real time system monitoring display

## Options

- 18" Side Delivery with hydraulic fold
- Permanent cross belt magnet, optional steel cladding
- Grizzly Bars with 2.5" spacing vs. grizzly fingers
- Lighting package mounted on engine housing
- Belt scale for under crusher conveyor
- Return chute for recirculation from off plant, optional flop gate and extension)
- 4 bar rotor (with 2 up, 2 down) vs. std.
- 18" return conveyor for recirculation from off plant, hydraulically lowers for transport
- Hydraulics for screen package (less screen)
- 6' x 12; double deck screen with cross and under screen conveyor (requires hydraulic package)
- CAT C13 440HP Tier III vs. Tier IV (international)
- Engine enclosure filter kit

## Physical/Operating Characteristics

Dimension	Standard	Metric
Travel Height	11' 11"	3.6 m
Travel Length	57' 4"	17.5 m
Travel Width	11' 5"	3.7 m
Operating Height	11' 11"	3.6 m
Operating Length	57' 4"	17.5 m
Operating Width	11' 5"	3.5 m
Operating Width w/ Discharge	15' 7"	4.7 m
Feed Height	11' 5"	3.5 m
Discharge Height	10' 6"	3.3 m

Dimension	Standard	Metric
Side Discharge (if equipped)	4' 7"	1.4 m
Ground Clearance	10"	0.3 m
Highest Estimated Decibel Level (Operating with No Material)	100dB @ 3' 70dB @ 200'	0.9 m 61 m
Total Weight	108,225 lbs	49,090 kg
Optional Hopper Extensions	3,300 lbs	1,497 kg
Under Crusher Conveyor	8,125 lbs	3,685 kg
Optional Magnet	4,750 lbs	2,154 kg
Feeder & Hopper	17,275 lbs	7,835 kg
Optional Side Delivery	1,530 lbs	694 kg

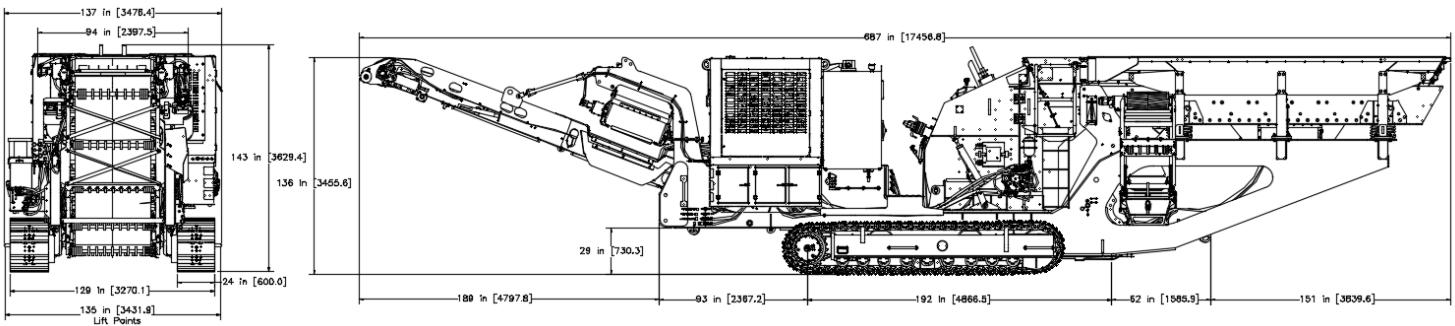
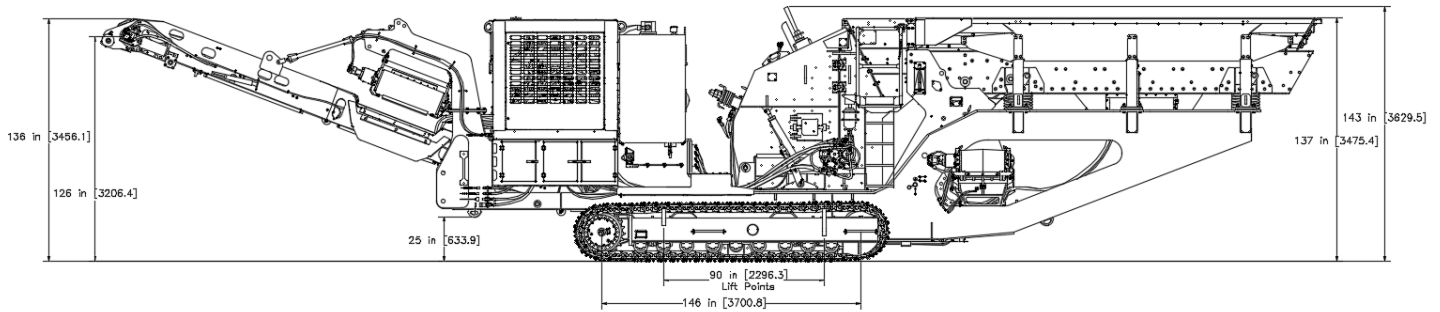
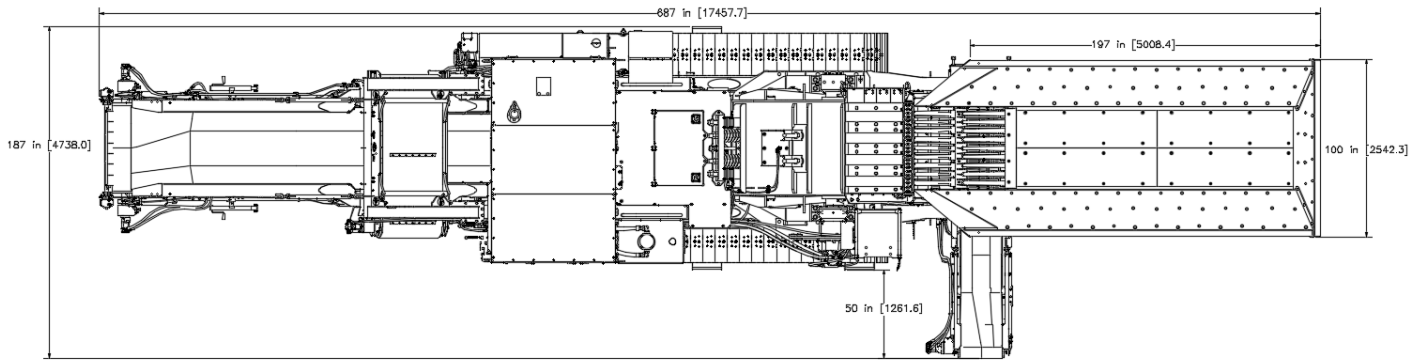

Kolberg-Pioneer, Inc.  
700 West 21st Street,  
Yankton, SD 57078  
1 (800) 542-9311  
mail@kpijci.com  
www.kpijci.com

**NOTE: CONSULT FACTORY FOR EXACT DIMENSIONS, specifications are subject to change without notice.**

Because Kolberg-Pioneer, Inc., Johnson Crushers International, Inc. and Astec Mobile Screens, Inc. may use in their catalog and literature, field photographs of their products which may have been modified by the owners, products furnished by Kolberg-Pioneer, Inc., Johnson Crushers International, Inc. and Astec Mobile Screens, Inc. may not necessarily be as illustrated therein. Also continuous design progress makes it necessary that specifications be subject to change without notice. All sales of the products of Kolberg-Pioneer, Inc., Johnson Crushers International, Inc. and Astec Mobile Screens, Inc. are subject to the provisions of their standard warranty. Kolberg-Pioneer, Inc., Johnson Crushers International, Inc. and Astec Mobile Screens, Inc. do not warrant or represent that their products meet any federal, state, or local statutes, codes, ordinances, rules, standards or other regulations, including OSHA and MSHA, covering safety, pollution, electrical wiring, etc. Compliance with these statutes and regulations is the responsibility of the user and will be dependent upon the area and the use to which the product is put by the user. In some photographs, guards may have been removed for illustrative purposes only. This equipment should not be operated without all guards attached in their normal position. Placement of guards and other safety equipment is often dependent upon the area and how the product is used. A safety study should be made by the user of the application, and, if required additional guards, warning signs and other safety devices should be installed by the user, wherever appropriate before operating the products.