

GT145

Mobile Screening Plant



Delivery Conveyor

- One (1) 34' x 41"(1050mm) conveyor hydraulic drive (300 FPM)
- Full-length skirt boards
- Chevron Belt, vulcanized

Product Conveyors

- Two (2) 35' x 25"(650mm) conveyors with swing out design
- Hydraulic variable speed (0 - 350 FPM)
- Chevron Belts, vulcanized

Fines Conveyor

- One (1) 29' x 47"(1200mm) conveyor hydraulic drive (350 FPM)
- Vulcanized

Overs Conveyor

- One (1) 30' x 25"(650mm) swing out design
- Hydraulic variable speed
- Chevron Belts, vulcanized

Feeder

- 13' x 1200 mm belt feeder
- Hydraulic variable speed drive (0-60 FPM)

Chassis

- 15" channel frame
- Track mount design
- Pendant remote control

Power System

- Cat 129 HP Tier III diesel engine
- Oil Cooler
- Engine mounted hydraulic pumps to operate all plant functions
- NEMA-4 rated instrument panel
- Emergency stop

Vibrating Screen

- 5' x 14' top and center deck, with a 12' bottom deck
- All decks have 1000 RPM adjustable amplitude capabilities
- Hydraulic controls for variable angle operation
- Aggregate spreader, access ladder with wrap around walkway

Hopper

- 8 cubic yard heaped capacity
- Hydraulic support legs
- Heavy duty 25° sloped grizzly with 6" openings
- Hydraulic remote dump with scissor action for easy cleaning

Plant Capacity

- 450 TPH (tonnages will vary with conditions)

Service Capacity

- 120 gal. fuel tank
- 130 gallon hydraulic system

Options

- 2 or 3 deck Vibrating Screen Configuration
- Hammer Mill Shredder
- Wireless Track Remote
- Tier IV Engine
- Ball Tray for Bottom Deck Module
- Screen Cloth
- 15' Feed Bin
- Rinser Package

Application Parameters

- Maximum Feed to Grizzly: 24" [730mm]
- Grizzly Spacing: 6"/152mm
- Maximum Top Deck Screen Opening: 4" [1200mm]
- Maximum Total Products: (3) sized, 1 oversize

Operating Slope

- Side to Side: 1% grade
- Front to Back: 3% grade

Physical/Operating Characteristics

Dimension	Standard	Metric
Overall Length	60' 2"	18.34 m
Travel Length	56' 11-1/2"	17.36 m
Operating Height	19' 4"	5.893 m
Travel Height	11' 6-3/8"	3.515 m
Operating Width	60' 1"	18.31 m
Travel Width	11' 5-1/2"	3.492 m
Unit Weight (2 Deck, 12' Feeder)	62,900 lbs	28,531 kg
Unit Weight (2 Deck, 15' Feeder)	63,500 lbs	28,803 kg
Unit Weight (3 Deck, 12' Feeder)	69,750 lbs	31,638 kg
Unit Weight (3 Deck, 15' Feeder)	72,500 lbs	32,886 kg
Feed Height	11' 3"	3.43 m

Operational Mode

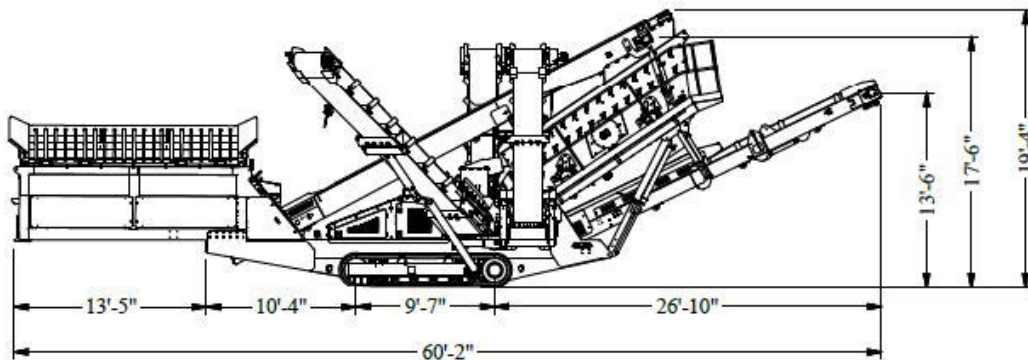

Transportation Mode

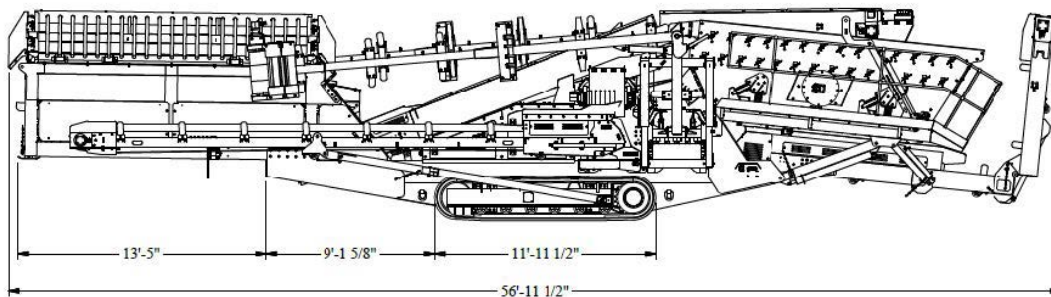

Astec Mobile Screens, Inc.
 2704 West LeFevre Road
 Sterling, IL 61081
 1 (800) 545-2125
 mail@kpijci.com
 www.kpijci.com

NOTE: CONSULT FACTORY FOR EXACT DIMENSIONS, specifications are subject to change without notice.

Because Kolberg-Pioneer, Inc., Johnson Crushers International, Inc. and Astec Mobile Screens, Inc. may use in their catalog and literature, field photographs of their products which may have been modified by the owners, products furnished by Kolberg-Pioneer, Inc., Johnson Crushers International, Inc. and Astec Mobile Screens, Inc. do not warrant or represent that their products meet any federal, state, or local statutes, codes, ordinances, rules, standards or other regulations, including OSHA and MSHA, covering safety, pollution, electrical wiring, etc. Compliance with these statutes and regulations is the responsibility of the user and will be dependent upon the area and the use to which the product is put by the user. In some photographs, guards may have been removed for illustrative purposes only. This equipment should not be operated without all guards attached in their normal position. Placement of guards and other safety equipment is often dependent upon the area and how the product is used. A safety study should be made by the user of the application, and, if required additional guards, warning signs and other safety devices should be installed by the user, wherever appropriate before operating the products.