



since 1905

# ULTIMA™ SERIES 35/40 TON CAPACITY



**NO FOOT**  
SELF-LIFTING GOOSENECK

SOME OPTIONAL EQUIPMENT  
MAY BE SHOWN.

The **ROGERS® ULTIMA™ Series CR40** - The high performance 40-ton capacity (with optional 3rd axle) detachable gooseneck trailer provides years of reliable, trouble-free service. It's 2-point load concentration is 80,000 lb. in any 12'-0" of the deck. The CR40 features the **No Foot®** self-lifting gooseneck, the **Croucher®** loading profile, and a "Bucket Pocket" in the deck. The 20" loaded deck height combined with the "Boom Trough" in the rear frame provides a remarkably low transport height.

## STANDARD FEATURES



■ The powerful **No Foot® self-lifting gooseneck** operates with low hydraulic pressure and does not push off the ground to lift. It can lift the rated load on any terrain and the deck height can easily be adjusted to clear obstructions above or below. The gooseneck also features extension blocks that can provide 4" of adjustment to the 5th wheel height. The gooseneck to deck connection is done with 6" wide mating hooks constructed from high-strength steel providing a strong, stable, positive connection for increased safety and durability.

■ The use of **high strength steel and superior manufacturing techniques** are the hallmarks of ROGERS trailers durability. Main and side beams are fabricated of 100,000 psi steel and the frames are assembled with full-width cross members that are pierced through the main beam webs for maximum structural strength. The maximum depth "Bucket Pocket" gives the lowest loading profile available for loading excavators on the platform deck. Sloped 30° bridge ramps give easy access to the rear frame.



■ **Lowered cross members in the rear frame** form a "Boom Trough" which allows excavators to be hauled as low as possible. The ULTIMA Series CR40 includes air ride suspension, LED light package, and preparations for an optional removable 3rd axle. LED strobe lights with shut-off switch are also standard equipment. The **Croucher®** frame front is tapered top and bottom for an optimal load angle. A variety of ramp options are available to best suit your loading needs and preferences.



**THE ULTIMATE IN TRAILERS®**  
**ROGERS BROTHERS CORPORATION**  
[www.rogerstrailers.com](http://www.rogerstrailers.com)

*The name you know, experience you can trust and the performance to back it up.*

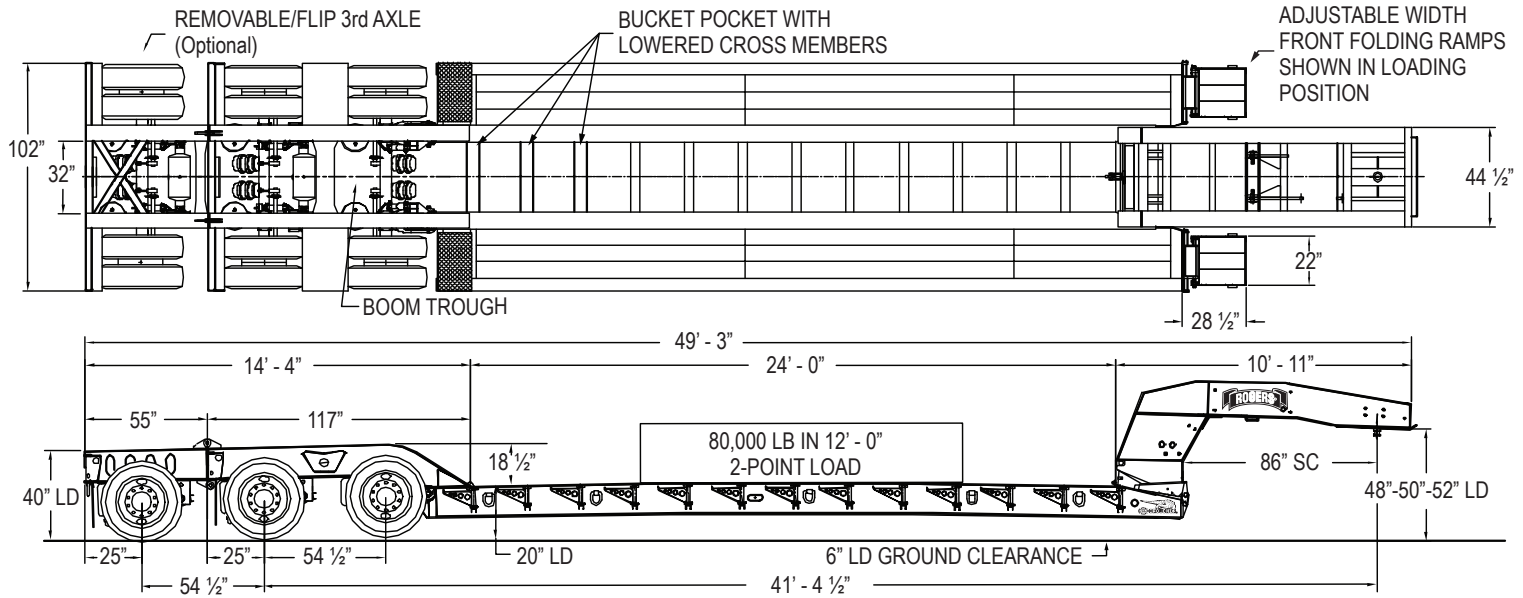

SPECIFICATIONS	MAXIMUM STRUCTURAL CAPACITY	SUSPENSION	AXLES	TIRES	WHEELS & HUBS/DRUMS	AIR BRAKES	GOOSENECK HYDRAULICS	EMPTY WEIGHT	GROSS VEHICLE WEIGHT RATING (GVWR)	GROSS AXLE WEIGHT RATING (GAWR)
	40 TONS IN 12' OF THE DECK (2-POINT) W/3RD AXLE	AIR RIDE WITH MECHANICAL HEIGHT CONTROL CAPACITY: 25,000 LB/AXLE	5" ROUND CAPACITY: 25,000 LB @ 60 MPH	255/70R22.5(H) LOW PROFILE TUBELESS RADIAL CAPACITY: 20,280 LB/AXLE	22.5" x 8.25" HUB-PILOTED 10-HOLE STEEL DISC WHEELS ON 16 1/2" x 7" DRUM	RISEING "S" CAM STYLE 4S/2M ABS W/SPRING PARKING BRAKES	MAX. PRESSURE: 2,000 PSI MAX. FLOW: 20 GPM	BASE MODEL: 18,100 LB +/- 3%	BASE MODEL: 98,100 LB +/- 3%	20,280 LB @ 60 MPH 25,000 LB @ 20 MPH

## STANDARD FEATURES

- 1/2 deck length 2- point load concentration.
- 14" deep cambered main beams fabricated with 100ksi steel.
- 24'-0" x 102" platform deck with 20" loaded deck height.
- Axle spacing 54 1/2".
- Dual-arm hydraulic gooseneck support jack with shoe.
- Hydraulic power source: Truck PTO.
- Full 1 3/4" air dried oak decking: No center boards.
- Twenty-six (26) side bracket bearings only.
- Ten (10) bent lashing D's (5 each side of deck).
- Sloped bridge ramps: 30° load angle to rear frame.
- Wide, load-bearing trunnions between tires.
- "Bucket Pocket" in rear of deck.
- "Boom Trough" of lowered cross members in rear frame.
- LED Lights: US DOT 12-volt rubber grommet mounted.
- Sealed wiring system with 7-wire socket.
- LED amber strobe lights in rear channel with recessed switch.
- Epoxy primer; ROGERS Red or Black enamel finish.

## OPTIONAL EQUIPMENT

- Removable swinging side brackets (shown above).
- Laterally adjustable front folding ramps (shown above).
- Other front folding ramps or wedges with grouser bars.
- Removable/flip 3rd axle.
- Center decking boards, installed or loose.
- Gooseneck fenders.
- 13 HP gas engine power unit.
- Hydraulic trap doors.
- Toolboxes - can be located in gooseneck or deck.
- Bar grating installed between main beams for storage.
- Welded, reinforced 1/4" smooth or tread plate wheel covers.
- Apitong decking.
- Wide/Oversize load sign and mounting bracket.
- Aluminum disc wheels.
- 275/70R22.5 (H) low-profile tires.
- Auxiliary light system with deep cycle battery.
- Backup warning alarm, electronic or mechanical.
- Other ROGERS paint colors available.

**ROGERS BROTHERS CORPORATION**

100 Orchard Street  
Albion, Pennsylvania, 16401  
(800) 441-9880  
(814) 756-4121  
(814) 756-4830 FAX  
www.rogerstrailers.com

**Highway Equipment Company**  
22035 Perry Highway  
Zelienople, PA 16063

**(800) 222-8798**  
www.highway-equipment.com