



BB705 Bark Blower
Trailer Mounted (BB705T)

FINN is excited to announce the addition of the new BB705 Bark Blower to its high-powered performance and productivity enhancing Bark Blower line. The new BB705 provides the ideal entry level option to the truck mounted power models. The BB705 has found its perfect niche integrating the technology and capabilities of the truck mounted series with the accessibility and operational ease of the trailer mounted units.

The BB705 Bark Blower provides options to enhance efficiency and utility. The optional seed injection allows for calibration of seed into compost or topsoil mixes for one-step seeding operations. This presents great opportunities for contractors wanting to enter markets in addition to mulch blowing, such as erosion control and seeding. The new BB705 increases utilization and profit. Optional front conveyor provides hydraulic feed during operation from a towing vehicle. This allows for continuous use of the unit.

Enhanced Features, Significant Benefits.

Greater Power, Less Fuel: Tier II Kubota V3300 71 hp engine increasing fuel efficiency and increasing hp to the blower

Versatile Material Handling: 4.5 cubic yard hopper, upgraded floor drive shaft, and increased running gear capacity allow for blowing a greater variety of bulk materials that are heavier such as soil, compost and high moisture mulch

Model shown may include optional equipment.

Increased Reliability, Reduced Service Costs: Advanced couplings replicating the truck mounted system, more robust hose reel, and new wiring harness relocated from high heated areas

Greater Accessibility: More accessible discharge outlet

More Efficient Design: To work efficiently in higher heat conditions the air cleaner has been placed to draw in cooler air, engine exhaust was reconfigured and engine cabinet door was perforated to minimize heat build-up inside the cabinet

Other standard features include a hydraulically powered rear mounted hose reel. An internal engine access panel, removable from inside the hopper, enables two-sided access to the engine compartment for inspection and maintenance. Floor speed read-out and precise speed settings are also standard. A rear hopper inspection platform, with ladder, provides convenient operator visibility into the hopper.

Versatility Comes Standard. The versatility of the BB705 conquers a vast array of applications including:

- Commercial/residential mulch beds, slopes, public gardens
- Playgrounds, amusement parks, sports field overseeding
- Soil/compost, erosion control/berms
- Aggregate installation, salt/sand spreading

Using the BB705, mulch can be applied on virtually any terrain, even in wet conditions.

SMARTER WAYS TO WORK

9281 LeSaint Drive • Fairfield, OH 45014-5457 • Phone (513) 874-2818 • Fax (513) 874-2914
Toll Free (800) 543-7166 • Parts (800) 229-8707 • E-mail: sales@finncorp.com
Customer Service/Warranty (888) 382-1966

BB705T TRAILER

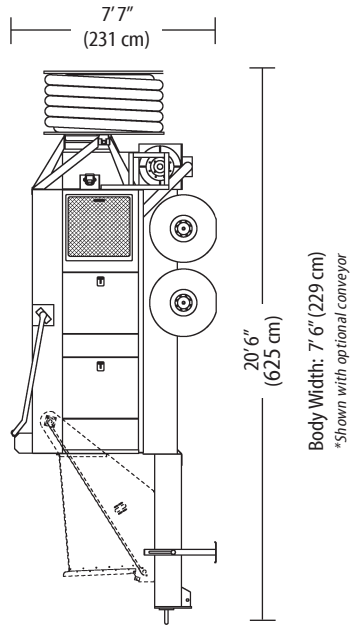

FINN MODEL BB705 TECHNICAL SPECIFICATIONS

POWER	Kubota V3300, diesel, 71 hp (53 kw)
ENGINE SAFETY SYSTEM	Low oil pressure, high water temperature shutoff
CAPACITY	4.5 cubic yd (3.6m ³)
HOSE REEL CAPACITY	150 ft (45 m)
FUEL TANK CAPACITY	28 gallon (106 liter)
BLOWER	820cfm @ 12 psi (23 cmm @ 88 kPa)
EMPTY WEIGHT	9,900 lbs. (4,490 kg)
WORKING WEIGHT*	14,700 lbs. (6,670 kg)
TRUCK REQUIREMENT	14,700 lbs. (6,670 kg) towing capacity MINIMUM

*Working weights are approximate and do not include options or stored materials.

FINN Corporation has a policy of continuous product improvement, and reserves the right to change design and specifications without notice.